

HX10M

STRENGTH IN THE MANUAL LIFTING



special
handling
solutions

See chart at pag. 48

The HX 10M series allows easier and lighter manual lifting up to a height of 800mm, creating a useful workbench suitable for places like mechanical workshops. It can also be used to support other machines in production, picking and similar areas.



Control lever

- All the controls (lowering / neutral / lifting) are available in a single lever for simple and safe control.



Front stabilizers (optional)

- The front stabilizers improve its balance, making the work easier even when lifting and working with heavy loads.



Rear stabilizers

- At a height of over 400mm, the rear stabilizers make the HX 10M a very safe and steady working platform, preventing rocking and movement in all directions.

CODE				GT042000000	GT044000000
MODEL				HX 10M	HX 10M
CAPACITY	Q	Load capacity	Kg	1000	1000
DRIVING SYSTEM	Escort			•	•
DIMENSIONS					
ELEVATION	h3	Total elevation	mm	800	800
	h2	Normal free elevation	mm	400	400
		Forks lowered height	mm	85	85
LENGTH	l	Fork length	mm	1150	1150
	nx51	Fork width x thickness	mm	160x48	160x48
	L	Total Length	mm	1526	1526
	B	Width	mm	540	680
WEIGHT	Empty weight			104	111
TURNING RADIUS	Wa		mm	1340	1340
STOWAGE PASSAGE	Ast	800x1200	mm	1840	1840
PERFORMANCES					
SPEED	Lifting with/without load		Nr	69/26	69/26
	Descent with/without load		m/s	0,06/0,04	0,06/0,04
WHEELS					
Driver / load side			Nr	2/2	2/2
Driver / load side			*	P/P	P/P

* G=Rubber, P=Polyurethane | Polyurethane load rollers as standard

OPTIONALS

FRONT STABILIZERS

CODE

EZ000500002

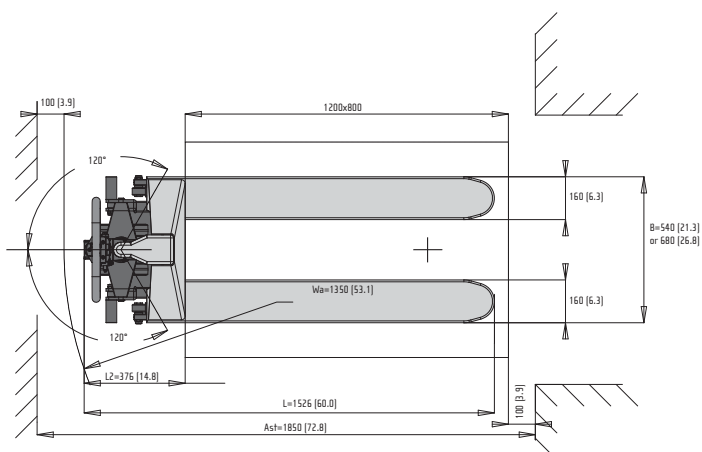
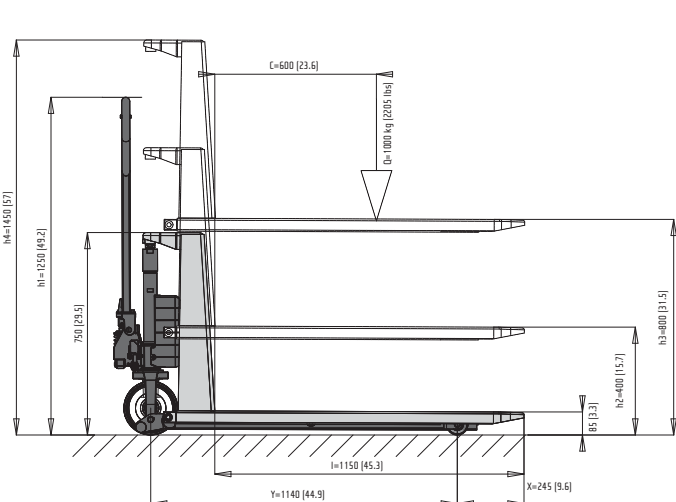

The producer reserves the right to introduce changes to models and features without prior notice.